

FABRICATION NOTE:

1. REFER TO TOLERANCES - FABRICATION UNO
2. REMOVE ALL BURRS & SHARP EDGES
3. MATERIAL: SG CAST IRON GRADE 500/320/7 TO AS1831
4. MATERIAL CERTIFICATE TO BE SUPPLIED
5. CAST SURFACES PAINTED COLOR BLACK USING SOLVENT BASED ACID ETCH SUPER ETCH PRIMER WATTYLE 239-MCRFC OR EQUIVALENT, SEE WEBSITE: WWW.WATTYL.COM.AU

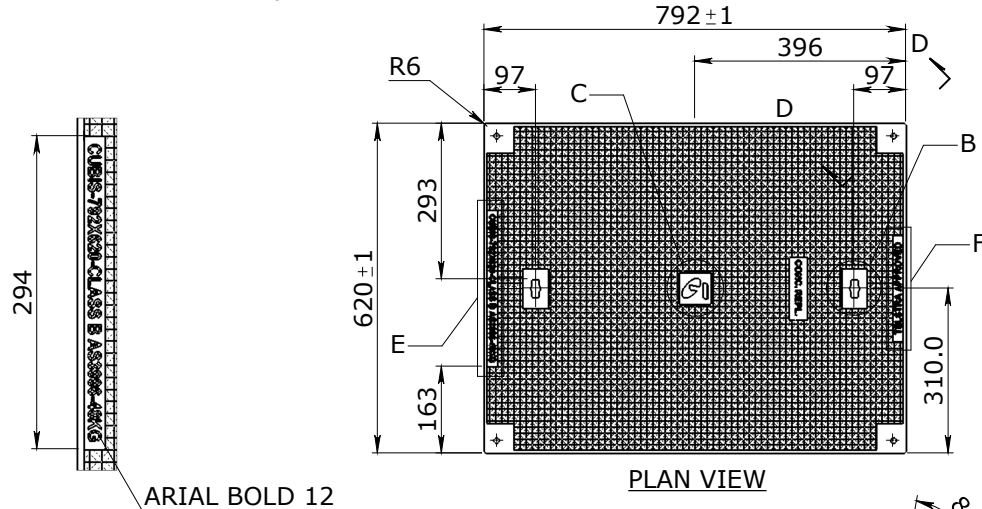

DETAIL E
SCALE 1:5

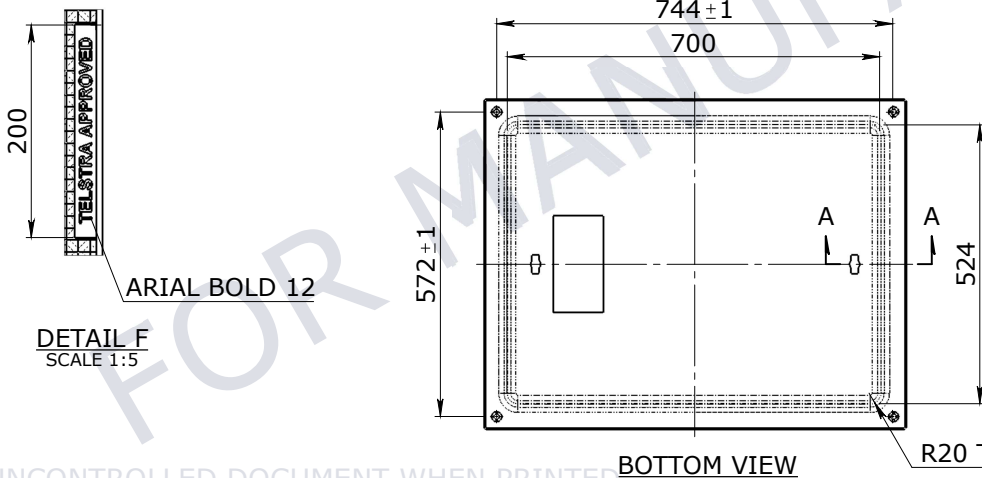

DETAIL F
SCALE 1:5

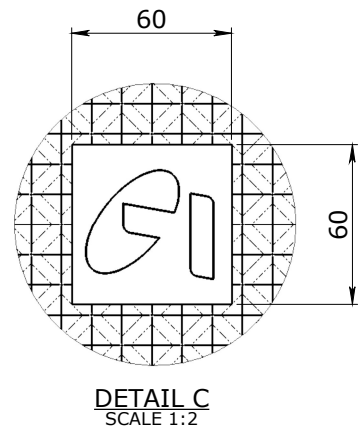
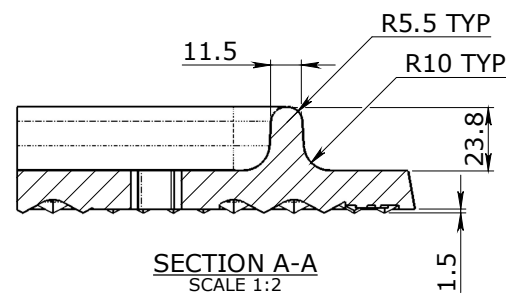
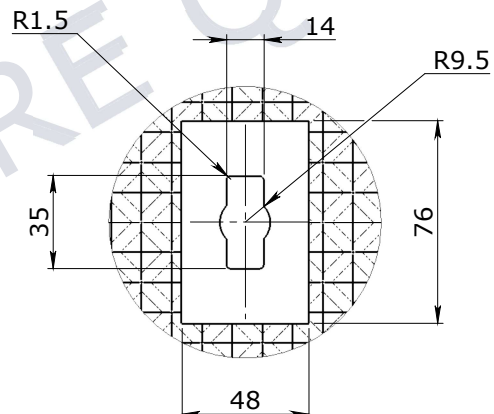
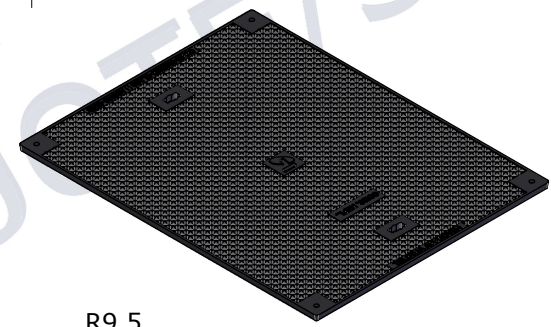
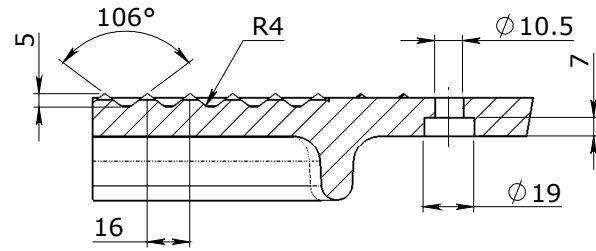

UNCONTROLLED DOCUMENT WHEN PRINTED

1. MATERIAL SPECIFICATIONS UNO
- SECTIONS & FLATS - AS 3679 - GR 300+
- PLATES AS 3678 - GR 250
- SHS AS 1163 - GR 350
2. WELDING TO COMPLY TO AS 1554.1 UNO

Rev	DESCRIPTION	DATE:	BY:	ECO#:

GENERAL TOLERANCES			
NOMINAL SIZE	UP TO 150	ABOVE 150 UP TO 500	ABOVE 500
TOL	±1.0	±2.0	±5.0

TOLERANCES - FABRICATION			REVISION CONTROL		
LINEAR X.XX ± 0.02	FACES SQUARE ⊥ 0.05/100	ANGULAR ∠ X.X ± 0°30' DIA. CONC WITHIN 0.05 TIR			
LINEAR X.X ± 0.1	FACES PARALLEL // 0.05/100	ANGULAR ∠ X ± 1° EDGES CHAMFERED 1.0 x 45°			
LINEAR X. ± 0.25	FACES FLAT ▽ 0.05/100	GENERAL SURFACE FINISH Ra 3.2			

CHK / APPR:	AC
DATE:	11/03/2019
REPEQ DOCUMENT #:	
WEIGHT:	48.81Kg
MATERIAL:	Malleable Cast Iron
SURFACE TREATMENT:	

HEAD OFFICE:
CARNINGHAM ROAD
BALLARAT, VIC 3351
(03) 5335 8741

ENGINEERING & DEVELOPMENT:
2 STRADBROKE STREET
HEATHWOOD, QLD 4110
(07) 3714 0444

THE INFORMATION DISCLOSED IN THIS DOCUMENT IS CONFIDENTIAL AND IS NOT WITHOUT THE EXPRESS CONSENT OF CUBIS SYSTEMS AUSTRALIA TO BE COPIED, REPRODUCED, OR GIVEN TO ANY OTHER PARTY IN ANY FORM AND THAT ALL COPYRIGHT, DESIGNS AND PATENTS VEST IN CUBIS SYSTEMS AUS.

PROJECT DESCRIPTION:					
CUBIS SYSTEMS AUSTRALIA CATALOGUE PRODUCTS					
DRAWING NAME: AX S™ MANHOLE COVER CAST IRON 792x620 CONC REPLACEMENT					
DRAWN TO AS 1100 DO NOT SCALE FROM SHEET	DRAWING No:	50201260	REV:	0	
SHEET: A3	PAGE: 1/1	SCALE UNO: 1:10	DRAFTED DATE: 25/06/2018	DRAFTED BY: YJ SHAN	